

CX12 S2 800X520 EVO

POWERFUL, COMPACT, MANOEUVRABLE



CX12

The CX12 electric pallet truck is suitable for carrying loads on smooth or paved surfaces. Its small size and turning radius make it the ideal tool to work with in confined spaces, such as lorries or narrow aisles.



EVO

EVO version is specifically designed to provide higher performance, reliability and speed through the innovative powerful three-phase AC technology, while reducing noise emission and overheating of the motor wheel.



AC TECHNOLOGY CONTROLLER

Powerful AC drive motor offering many advantages and more efficiency: higher level of duty, performance and reliability.



EVO BATTERY PACK

Strong ABS cover with storage tray on top, easily removable for a simple access to batteries and key components speeding up maintenance operations.

Schuko plug with spiral cable available for an easy charging.



TILLER EVOLUTION EPT

Fully integrated ergonomic technopolymer tiller system including fingertip throttle and fork controls, safety pushbutton, horn, turtle button, hourmeter, battery status indicator as standard equipment.



TURTLE FUNCTION

Ergonomic dedicated button as standard for moving the unit in tight areas with the handle in vertical position while remaining almost within the profile of the machine.



EMERGENCY PUSH BUTTON

Very practical system with key and emergency function in the same button. The key is removable and pocket-sized when the operator leaves the machine unattended.



ROLLERS

Standard configuration provided with single polyurethane rollers. Available tandem rollers as optional.



Descriere

1.1 Producător			LIFTER
Stivuitoar			ELECTRIC
1.3 Comandă			ELECTRIC
1.4 Poziție operare			Pedestru
1.5 Capacitate maximă	Q	Kg	1200
1.6 Distanța la centrul de aplicare al sarcinii	c	mm	400
1.8 Sarcina de la osie la capătul furcilor	x	mm	536
1.9 Ampatament	y	mm	769

Greutăți

2.1 Greutate de operare (acumulator inclus)		Kg	160
2.2 Sarcină osie, încărcare pe spate		Kg	1017
2.2 Sarcină osie, încărcare pe față		Kg	343
2.3 Sarcină osie, liber față		Kg	131
2.3 Sarcină osie, liber spate		Kg	29

Cauciucuri/Șasiuri

3.1 Cauciucuri: roți direcție			CAUCIUC
3.1 Cauciucuri: roți stabilizatoare - Față			POLY.I.
3.1 Cauciucuri: transportoare cu role			NYLON
3.2 Mărime cauciuc: roți direcție - Lățime		mm	50
3.2 Mărime cauciuc: roți direcție - Diametru		mm	186
3.3 Mărime cauciuc: transportoare cu role - Diametru		mm	82
3.3 Mărime cauciuc: transportoare cu role - Lățime		mm	82
3.4 Mărime cauciuc: roți stabilizatoare față - Diametru		mm	75
3.4 Mărime cauciuc: roți stabilizatoare față - Lățime		mm	25
3.5 Dimensiune cauciuc: roti spate		nr	2
3.5 Dimensiune cauciuc: roti fata		nr	1x
3.6 Ecartament, față	b10	mm	369
3.7 Ecartament, spate	b11	mm	371

Dimensiuni

4.4 Înălțime stivuitoar	h3	mm	115
4.9 Înălțime manetă în poziția de deplasare, max	h14	mm	1345
4.9 Height of tiller in drive position min	h14	mm	885
4.15 Înălțime, coborât	h13	mm	85
4.19 Lungime globală	l1	mm	1160
4.20 Distanța până la suprafața frontală a furcilor	l2	mm	360
4.21 Lățime globală	b1	mm	520
4.22 Dimensiuni furcă - grosime	s	mm	55
4.22 Dimensiuni furcă - Lățime	e	mm	150
4.22 Dimensiuni furcă - Lungime	l	mm	800
4.25 Distanța între furci	b5	mm	520
4.32 Gardă la sol și mijloc ampatament	m2	mm	30
4.34 Lățime culoar	Ast	mm	1382
4.35 Rază de virare	Wa	mm	918

Performante

5.1 Viteză de deplasare cu incarcare	Km/h	5.0
5.1 Viteză de deplasare fără incarcare	Km/h	5.0
5.10 Frână de serviciu		REVERSE CURRENT BRAKING

Motoare electrice

6.6 Consum de energie în ciclu VDI	kWh/h	0.28
8.4 Nivel sonor la nivelul urechii șoferului	dB(A)	67

*Integrated battery and battery charger

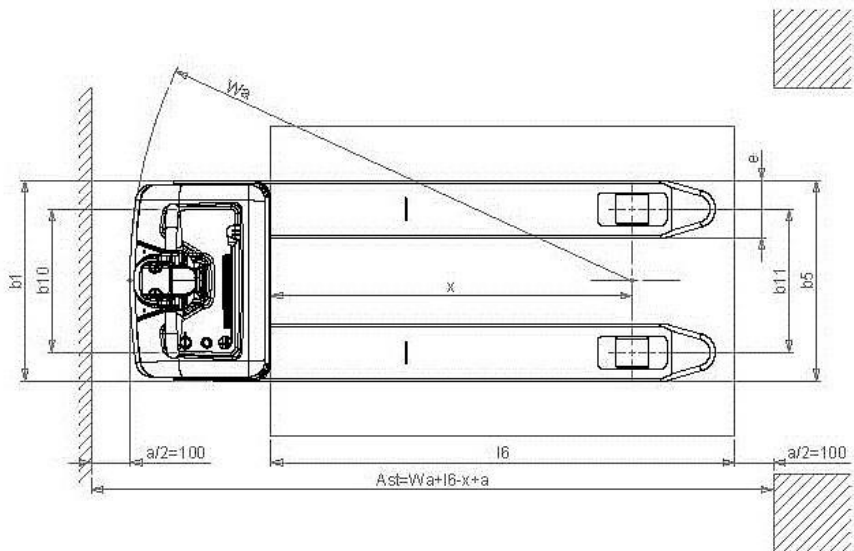
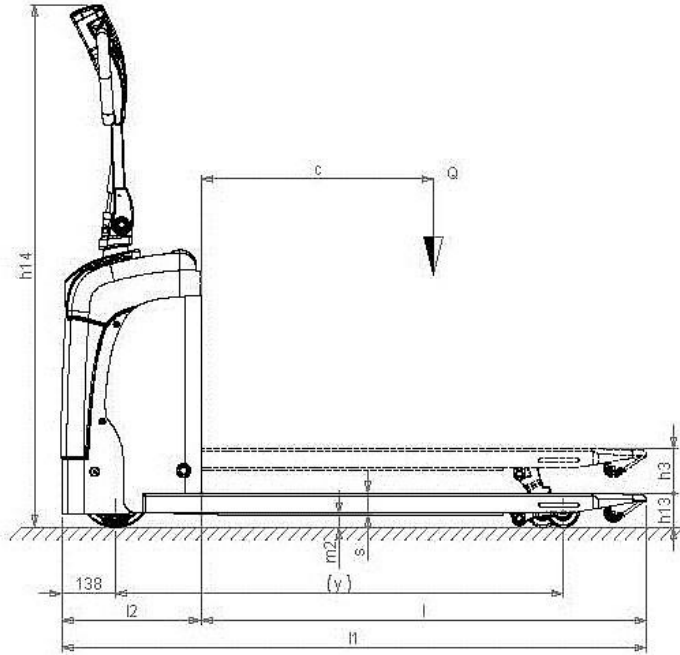

The information is aligned with the Data file at the time of download. Printed on 24/02/2020 (ID 10471)

©2019 | PR INDUSTRIAL s.r.l. | All rights reserved | Image shown may not reflect actual package. Specifications subject to change without notice

